



Pixii Home Off-grid Box

Enables off-grid operation with PV and genset

The off-grid box is designed for safe disconnection and isolation of Battery Energy Storage Systems (BESS) from the grid, in off-grid and hybrid systems.

Compatible with both the AC and hybrid versions of Pixii Home.

Prepare Pixii Home for off-grid operation

The primary function of the off-grid box is to automatically disconnect from the grid and initiate off-grid operation for critical loads. The transition typically occurs in less than 5 seconds.

Once the grid is stable again, critical loads are reconnected to the grid, and Pixii Home resumes normal operation in grid-tied mode.

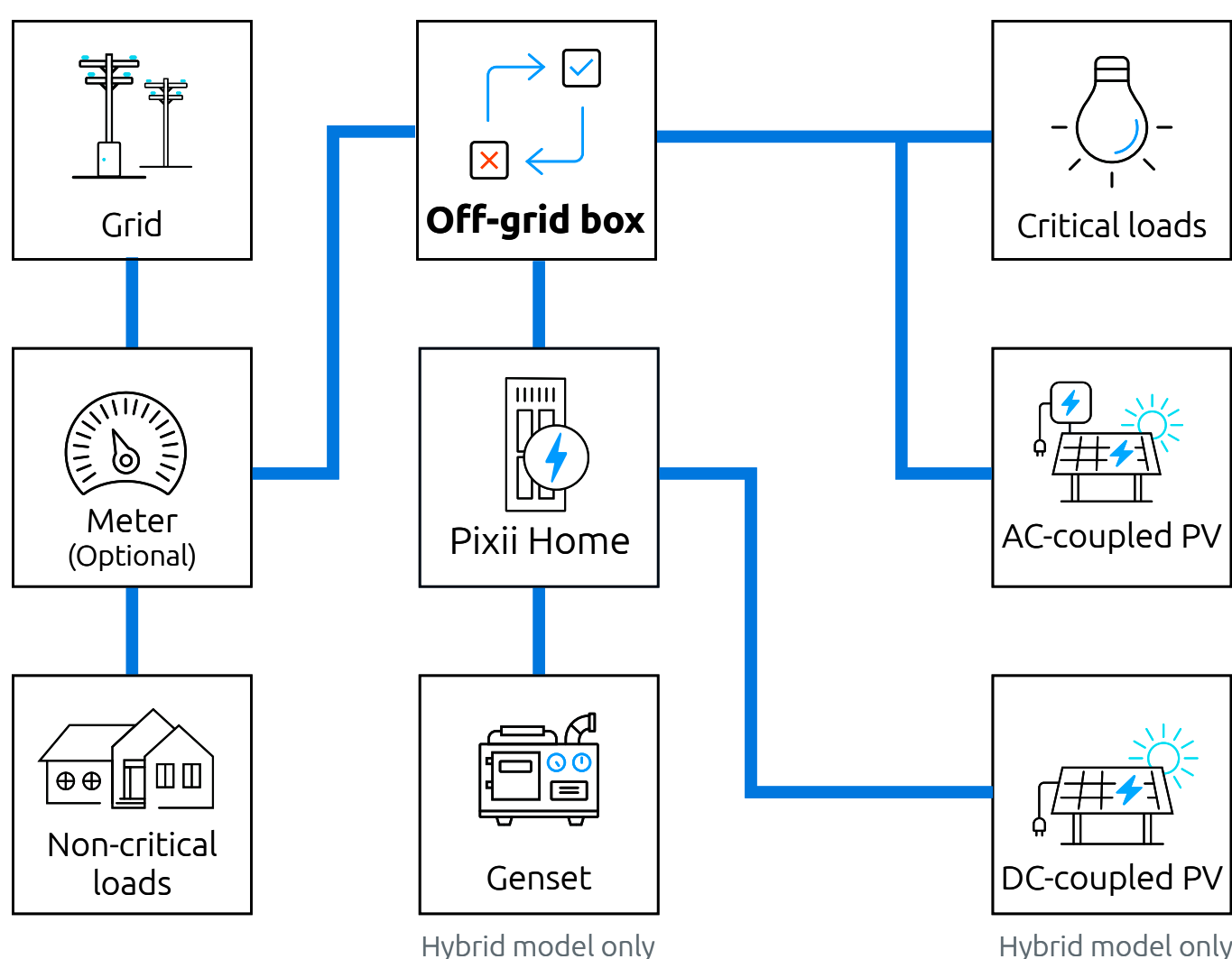

Highlights

- Supports both 1- and 3-phase systems
- 10kVA 1-ph/50A | 20kVA 3-ph/32A
- Frequency droop control for solar integration
- Capable of motor start-up
- Black start functionality
- Multiple transition start methods available

Key functions

- Backup power
- PV self-consumption
- Power congestion relief



The Pixii Home Off-grid Box can be used on both the AC and hybrid version of the Pixii Home BESS.

Pixii Home Off-grid Box

AC specifications	
Nominal AC voltage	230/400V
Nominal frequency	50 or 60 Hz
AC output current (off-grid)	1ph/50A
AC output current (off-grid)	3ph/32A
Grid compatibility ¹⁾	TN, TT
Max. AC current (mains port)	63A
Max. AC current (backup port)	63A

1) IT grid connection is not supported in the current release. For TT grid connection, 3-phase 4-wire + local PE.

Performance and efficiency	
Transition time (grid to off-grid)	<5 s
Transition time (off-grid to grid)	<3 s

Physical specifications	
Dimensions (HxWxD) (mm)	689 x 319 x 146
Net. weight (fully equipped)	8 kg
Color	RAL7035
Material	Plastic
Empty DIN rail space ¹⁾ (mm)	70

1) Can be used for optional DIN rail meter installations or additional load breakers

Operating conditions	
Operating environment	Indoor, outdoor
Operating temp. range	-20 to +50 °C

Safety	
Ingress Protection (IP)	IP65
Protection class	I
Overvoltage Category (OVC)	II
BESS isolation switch	63A
Max. short-circuit rating	10kA
Emergency switch	Optional input

Compliance and warranty	
Safety standards	
IEC/EN 61439-2 ¹⁾	

1) Build according to

Functions

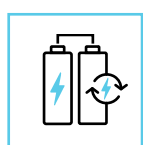

Backup power

Maintain power supply to critical loads from the battery during grid outages.



PV self-consumption during outages

Utilize both AC- and DC-coupled PV systems during grid outages, with AC frequency regulation to stabilize local power supply.

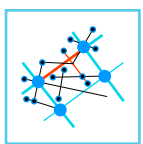

Power congestion relief

Increase peak power availability beyond transformer, line, or fuse limitations to handle local consumption peaks.

Functions

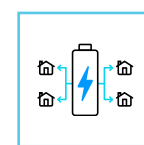

Microgrid operation

Supply power in a locally isolated grid using PV and/or generators, optimizing solar utilization and reducing fuel consumption per kWh.



Phase balancing¹⁾

Control active and reactive power per phase to distribute loads more evenly and support power quality.

1) Phase balancing is available only when integrated via an external EMS (Energy Management System). Load balancing is achieved by controlling P and Q per phase.